

CGM-Series User Manual

Positive Displacement Gear Flow Meters



CGM1

max
Precision Flow Meters

Safety and Precautions



Do not exceed mounting holes torque limit. Maximum Torque: 5 in-lb. Over torquing will damage the meter. See CGM1 mechanical Dimensions Specifications section [page 14](#).



Never run the meter dry or blow compressed air through the meter. Damage will occur.



Never steam clean the meter. Damage will occur. (Bypass or remove the meter if necessary).



Do not disassemble the meter. Damage may occur. No serviceable parts inside.



Do not over pressurize the meter. Damage may occur.



Do not remove the transmitter from the flow meter body unless advised by Max. Re-phasing the transmitter to the flow meter body via the Interface Software Kit is required to prevent measurement errors.



Do not apply excessive differential pressure across the flow meter. Damage will occur. See pressure drop curves for safe area operation, section [page 15](#).



Do not exceed maximum flow rate for the material viscosity. Damage will occur.



Do not allow materials to cure in the flow meter. If materials cannot be flushed from the meter, damage may occur.



Do not flow remeltable materials through the meter until fully liquefied. Solids may damage the meter.



Read the entire manual before installing and operating the meter.



Install meter as shown in Meter Orientation section [page 2](#).



Verify the fluid to be measured is compatible with the flow meter.



Filter your fluid to prevent damage from debris and foreign materials.



Install bypass plumbing around the flowmeter to allow for easier servicing and line purging/flushing without damaging the meter.



Follow all local regulations and your company's safety procedures when installing, operating, servicing, and maintaining your flow meter.

Table of Contents

Safety and Precautions.....	i
Table of Contents.....	ii
How It Works	1
Installation Mechanical.....	2
Mechanical Operation	4
Electrical Installation	5
Installation Electrical Quick Start.....	6
Electrical Installation Instructions	7
Electrical Operating Information	8
High Temperature Instructions	9
Field Compensation of the Transmitter	10
LED Functions.....	12
Specifications (Frequency).....	13
Specifications (Analog)	14
Dimensions.....	15
Part Matrix.....	16
Available Accessories	18
Troubleshooting and Service Request.....	19
Additional Information Available.....	19

Max Machinery, Inc. (MMI) reserves the right to change product specifications without notice to improve performance, reliability, or manufacturability. MMI shall not be held liable for operational, technical, or editorial errors/omissions. Visit our web site for the latest version of this user manual.

Max Machinery, Inc., 33A Healdsburg Avenue, Healdsburg, CA 95448 USA
707.433.2662 | www.maxmachinery.com



How It Works

General Description

The Max CGM-Series Precision Flow Meters are positive displacement gear meters constructed from materials that can withstand harsh chemicals and designed for accurate measurement of liquid flow over a wide range of flow rates and fluid viscosities. Measurement accuracy is achieved through precision-machined spur gears that rotate proportionally to the fluid flow. The gear rotation is detected and converted into analog or frequency output signals, providing high-resolution flow data for industrial monitoring and control.

The CGM-Series supports flow rates from 0.5 cc/min to 2 liters/min, fluid temperatures from -15°C to 70°C, and system pressures up to 250 psi (17 bar). Optional seal materials are available to ensure compatibility with a wide range of process fluids.

The transmitter is housed in an IP65-rated enclosure, providing protection against dust, water, and most corrosive fluids encountered in process environments.

Quality and Calibration

Max Machinery, Inc. designs, manufactures, calibrates, and refurbishes high-accuracy, high-resolution precision liquid flow meters under an ISO 9001:2015 certified quality management system. Each Max Precision Flow Meter is fully tested and calibrated in our laboratory, and all measurement data is traceable to NIST standards.

If the calibration certificate for your meter is lost or unavailable, contact Max Machinery with the meter's serial number to request a replacement.

Installation - Mechanical

Installation Overview

Your Max CGM Flow Meter is factory-configured for immediate use based on the application data provided at the time of order. Simply plumb the meter, wire it, and begin operation. Follow the flow-direction arrows on the meter body to ensure correct installation. Whenever possible, install the meter on the discharge side of the pump, and avoid excessive vibration at the mounting location.

For outdoor installations, Max Machinery recommends using additional shielding or protective housing to reduce long-term exposure to UV radiation and weather.

Meter Orientation

The preferred mounting orientation depends on the meter type and is intended to optimize air purging and minimize heat transfer to the electronics. For CGM-Series meters—especially in applications involving viscous fluids—mount the meter in the Vertical Flow Direction. This orientation helps eliminate trapped air pockets that could otherwise cause response delays or measurement errors.

CGM recommended orientation

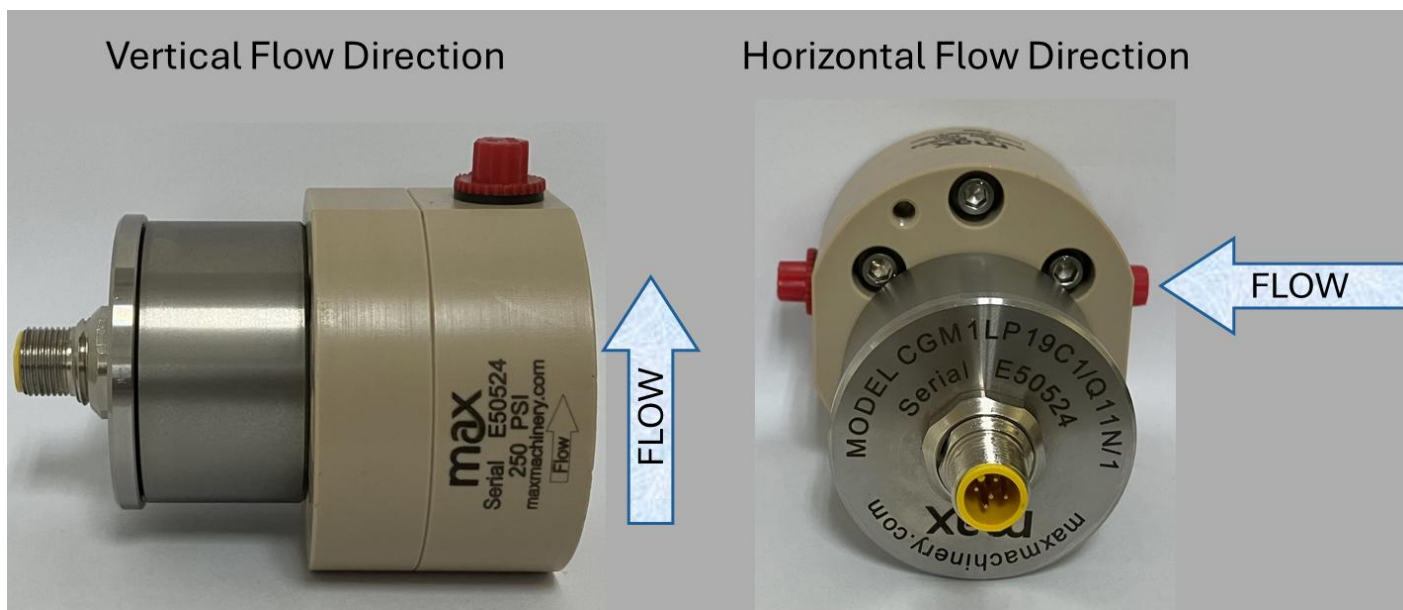

NPT fittings: Use pipe tape during installation, leaving the first thread exposed. Take care to prevent tape from entering the meter.

BSPP fittings: Apply a lubricant compatible with the process fluid to the O-ring before attaching the fitting to the meter.

Installation - Mechanical

Bypass Valves: Install bypass valves to enable system start-up, filter changes, or meter removal without fully shutting down or draining the system. (Refer to diagram.)

Filtration: A 10-micron filter is recommended on the inlet side of the meter for CGM flow meters. If measuring bi-directional flow, a filter should be installed on both sides of the flow meter. Materials with fibrous or non-abrasive particulate matter may need to be run without filters.

Clean Plumbing: Ensure all system lines are clean and free of debris or manufacturing residue before installing the flow meter. While compressed air or steam may be used to purge the system, **do not** apply them directly to the CGM-Series flow meter, as this will cause damage.

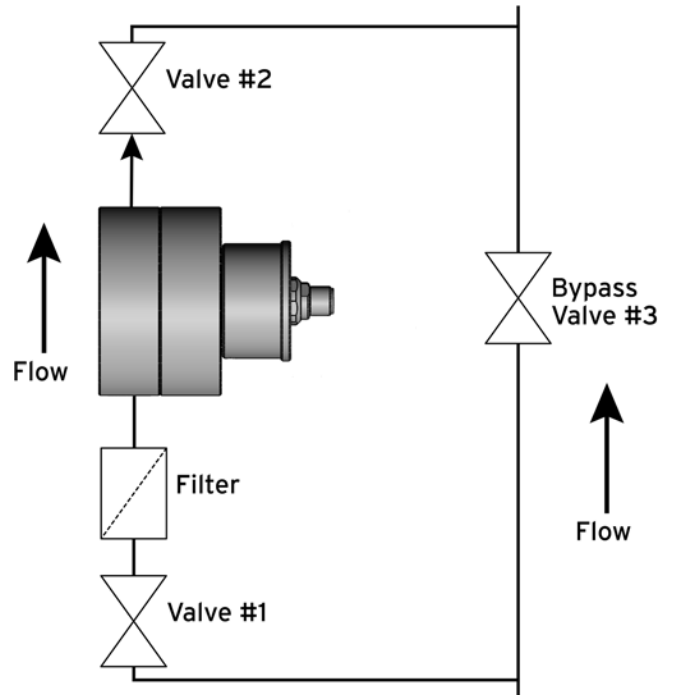

High Temperature: Orient the transmitter to the side or below the flow meter to reduce heat transfer by convection. This protects the transmitter, which is the most heat-sensitive component in the system.

Insulation Protocol: If insulation is required, insulate only the flow meter body. Leave the transmitter housing exposed to allow heat to radiate away safely.

Temperature Limits: Refer to [page 8](#) of the product documentation for maximum fluid and ambient temperature specifications.

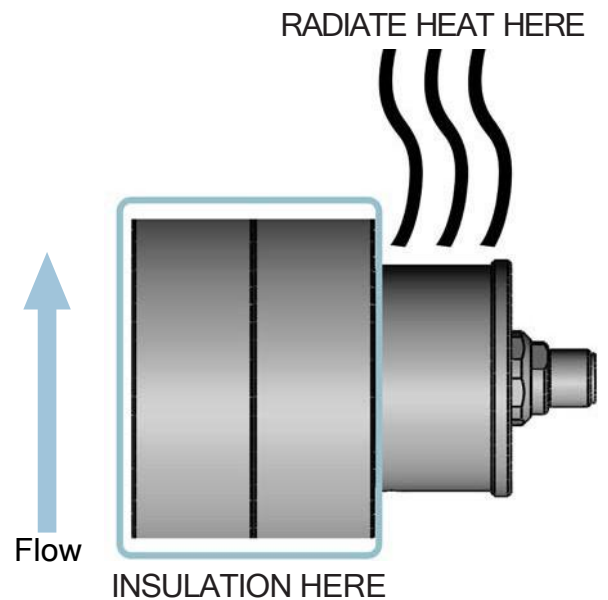

Mechanical - Operation

System Verification Prior to Start-Up

Before operating the Max CGM Flow Meter, verify that all system parameters are within the allowable specifications for the specific meter model being used:

- Maximum System Pressure
- Differential Pressure across meter (See Pressure Drop Curves)
- Maximum Flow Rate (See Pressure Drop Curves)
- Ambient and Metered Fluid Temperature (See page 8)

First time flowing fluid through meter

1. Start with Valve #1, #2, and #3 closed.
2. Slowly open Valve #3 (bypass) to clear foreign particles and air from system. Continue flowing through bypass valve as long as needed to clear all debris and air from system.
3. Slowly open Valve #1 (inlet).
4. Slowly open Valve #2 (outlet).
5. Fully close Valve #3 (bypass).

High Temperature Startup Procedure

Shocking the meter with high temperature fluid can cause the metering elements to expand faster than the housing, causing the meter to bind until temperatures are allowed to stabilize. If a large pressure drop is applied to the meter before temperatures stabilize, the meter can be damaged. If the metered fluid temperature is more than 25°C (45°F) above ambient, follow the High Temperature Start-Up procedure below:

1. Start with Valve #1, #2, and #3 closed.
2. Slowly open Valve #3 (bypass) until temperature is stabilized in bypass circuit.
3. Slowly open Valve #1 (inlet).
4. Slowly open Valve #2 (outlet).
5. Wait 1 minute for every 25°C (45°F) that the fluid temperature is above ambient (i.e.: wait 2 minutes for fluid temp. of 70°C and ambient temp. of 20°C)
6. Fully close Valve #3 (bypass).

Maintenance Requirements

No routine maintenance, cleaning, or lubrication of the flow meter is required. Establish a regular filter cleaning schedule to maintain system performance. The system should be shut down if abnormal noises occur or if unusual differential pressure across the meter is observed.

Installation - Electrical



WARNING: Electrical shock hazard. Serious or fatal injury may occur. Installation or removal should only be performed by trained and authorized personnel.



CAUTION: Verify transmitter output type (Analog or Frequency) before wiring. Inappropriate wiring could result in damaging the circuit.



CAUTION: Before opening/accessing the electronics lid, make sure the top of the meter and surrounding components are dry, and no moisture or fluids can contact the electrical components. Non-warranty damage may occur.

Max CGM-Series Precision Flow Meter transmitters are factory-assembled with the mechanical metering component and pre-configured for immediate use based on your submitted application data. Simply plumb, wire, and operate.

There are various combinations of transmitter components and outputs. These options include:

- Frequency or Analog Output Signal
- Uni-directional or Bi-directional Output Signal

To identify your transmitter type, refer to the part number matrix on [page 16](#) and decode your flow meter's part number.



Installation - Electrical

Quick Start - No adjustments to factory settings

The CGM Flow Meter connects to your process automation system through the 5-pin M12 Turck connector located on the transmitter lid.

1. Wire the 5-pin Turck cable to your automation equipment according to the wiring diagrams supplied for your CGM Industrial transmitter. Once wiring is complete, connect the cable to the Turck connector on the transmitter.
2. Set your process interface output to match the values on the calibration sheet provided with your flow meter.

After wiring and configuration, the system is ready to measure your liquid flow application.

Start-up Instructions - Adjustments to Factory Settings Required

If you need to make any adjustments to your Max Flow Meter prior to use, you will need to purchase and use the Max Machinery Interface Software Kit. This will allow you to change the flow meter output signal frequency or analog range to meet your application equipment needs.

To access the port on the circuit board, unscrew the transmitter lid by hand. The transmitter lid has four thread paths. When reinstalling the lid, the cable may be misaligned. To realign the cable, remove the lid and rotate up to 180° and retighten using an alternate starting point. Tighten to compress the O-ring seal.

Max Flow Meters do not come with a visual interface, they must be connected to an electronic display, PLC/DAC/counter card, or other process automation electronics to collect the data and display a visual reading.

You must determine if your process automation electronics have the capability to accept the high frequency output of the Max Flow Meter. If your system cannot accept the data at the pre-set frequency, then use the Max Machinery Interface Software Kit to adjust the frequency output to a lower setting that matches your system.

Refer to the Max Machinery Interface Software Kit Manual for instructions on how to change the flow meter output signal frequency or analog range to meet your application equipment needs.

Electrical Installation Instructions - 5-pin Turck Connectors

Applies only to transmitters with 5-pin, M12 style connectors.

Frequency Output Transmitters (PN ending N/-)

	Turck® Connector		
	PCA Label	Pin #	Mating Cable Wire Color
Power (+5 to 26 Vdc)	V+	1	Brown
Common	Com	4	Black
Pulse Output	Ph A	2	White
Output Phase B (Quad only)	Ph B	5	Grey
Case Ground	Case	3	Blue



Current Sinking Wiring (PN ending S/-)

A current sinking device uses the transmitter's transistor output to function as a switch. Positive DC voltage must be applied to the transmitter's output pin #2. When the pulse output is triggered, this voltage is grounded to zero volts by the transmitter. Warning: Use a 5k ohm resistor to limit current if your system does not have other means to limit current into the transmitter.

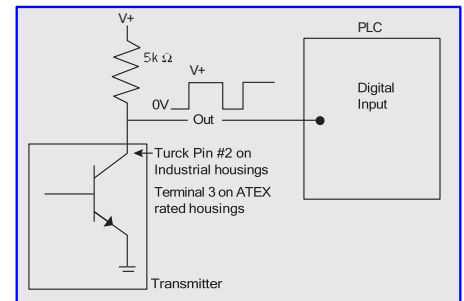

Analog Current or Voltage Output Transmitters (PN ending A/-, B/-, C/-, or D/-)

	Turck® Connector		
	PCA Label	Pin #	Mating Cable Wire Color
Power *	V+	1	Brown
Common	Com	4	Black
Signal Output (+)	Sig	5	Grey
Signal Output (-)**	Ret	2	White
Case Ground	Case	3	Blue



* Analog transmitters with part numbers ending in A/- or C/- are 24Vdc power. Part numbers ending in B/- or D/- are 12Vdc power.

** To minimize signal noise, analog output transmitters are fully isolated. If your PLC does not ground the negative signal input, there is a risk of a ground shift that could drive the signal out of the range of detection. To prevent this from occurring, install a 10k ohm pull down resistor between Common and Signal Output (-).

Electrical - Operating Information

Max Flow Meters require a fully isolated power supply to operate. Refer to the Max Machinery Interface Software Kit Manual for instructions on how to change the flow meter output signal frequency or analog range to meet your application equipment needs.

Transmitters should not be removed from the flow meter for any field service or adjustments. The flow meter and transmitter must be shipped back to the factory for calibration or service as the complete serialized unit.

Moisture Seal Protection

On all models, the housing is designed as a liquid and vapor-tight enclosure. There are O– ring seals between the lid and the housing which need to be fully seated. A properly sealed transmitter will prevent the formation of damaging moisture inside the housing. Industrial transmitters have Turck connectors sealed to the lid at the factory and are ready for use. There are no adjustments or services settings that require the connector to be removed from the transmitter lid.

Derating of Ambient and Fluid Temperature Limits

The CGM-Series Industrial transmitters are rated to operate over a fluid and ambient temperature range of -15°C to 70°C (5°F to 158°F).

For ambient temperatures above 40°C (104°F), the maximum fluid temperature rating may decrease (below 70°C) depending on transmitter output type and supply voltage. Consult factory for additional information.

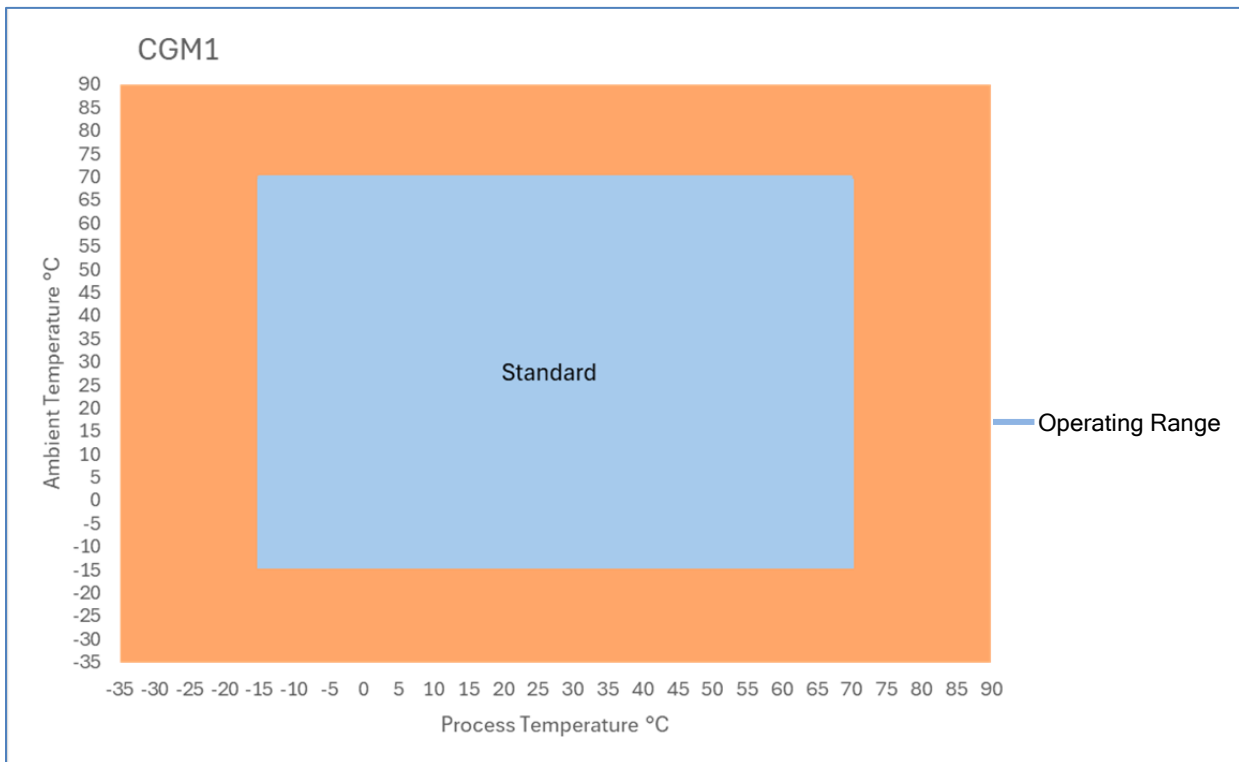

High Temperature Instructions

FOR FLUID TEMPERATURES 40°C (104°F) OR ABOVE: To minimize heat transfer, the transmitter must be oriented to the side or below the flow meter. This reduces heat transfer by convection to the transmitter, which is the most heat-sensitive component in the system. When insulating the system, insulate only the flow meter body. Do not insulate the transmitter housing—leaving it exposed is necessary for proper heat dissipation and to prevent heat-related damage. Always confirm that the fluid and ambient temperatures fall within the limits specified on [page 8](#).

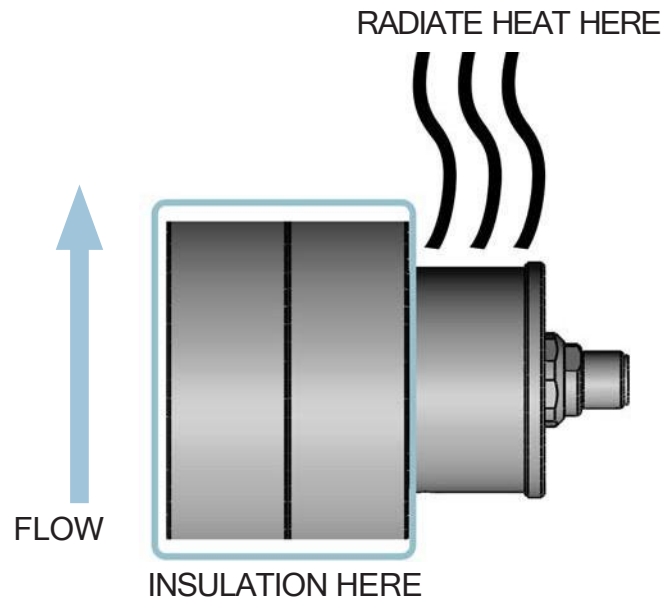

Troubleshooting

LED Rotation/Output Indicators

All Max transmitters incorporate an alternating red/green or blue/green LED to indicate magnet rotation in the meter. The color changes each 1/2 revolution of the meter. Additionally, when no flow signal is present, a rapidly flashing red light indicates the following errors:

Frequency (PN ending N/- or S/-):	Flashes 8x per second indicates magnet is not detected
Analog (PN ending A/-, B/-, C/-, D/-):	Flashes 2x per second indicates excessive temperature
	Flashes 8x per second indicates magnet is not detected
	Flashes 16x per second indicates wiring fault in the output circuit

Note: There are no selections or adjustments on the circuit board. Changes to settings are made via the Interface Software Kit (SFT-KIT-001), sold separately.

Field Compensation of the Transmitter

The transmitter LED on the circuit board indicates a functioning system when it is producing a pulse output or detecting magnet rotation in the meter.

An alternating blue/green LED indicates that the circuit is detecting a magnet and provides an output signal.

A steady or flashing red LED indicates a problem with the transmitter PCA. Contact Max Machinery to have your Flow Meter refurbished.

The Compensation Algorithm adjusts for variations in Hall sensor and flow meter characteristics to provide a stable, undamped output frequency that accurately represents the instantaneous flow rate. This feature is factory set when the meter is assembled. If the transmitter PCA is replaced or reset, the compensation can be performed via the gold PCA button or through the software kit.

The only method of altering additional factory set parameters of the meter is through the Interface Software Kit, part number SFT-KIT-001. Pulse Output Scaling, Analog Output Limits and Scaling, Signal Filtering Options and Compensation settings are the adjustable variables.



WARNING: Electrical shock hazard. Serious or fatal injury may occur. Access should only be completed by trained and authorized personnel.



CAUTION: Before opening/accessing the electronics lid, make sure the top of the CGM1 meter and surrounding components are dry and no moisture or fluids can contact the electrical components. Non-warranty damage may occur.

Instructions to access the gold PCA button and software serial port:

- Remove and set aside the lid with O-ring seal.
- Optional: follow instructions for SFT-KIT-001 to connect to software serial port.
- Follow field compensation instructions on [page 11](#).
- To reinstall, ensure the O-ring seal is firmly seated. Assembly is then the reverse of disassembly.

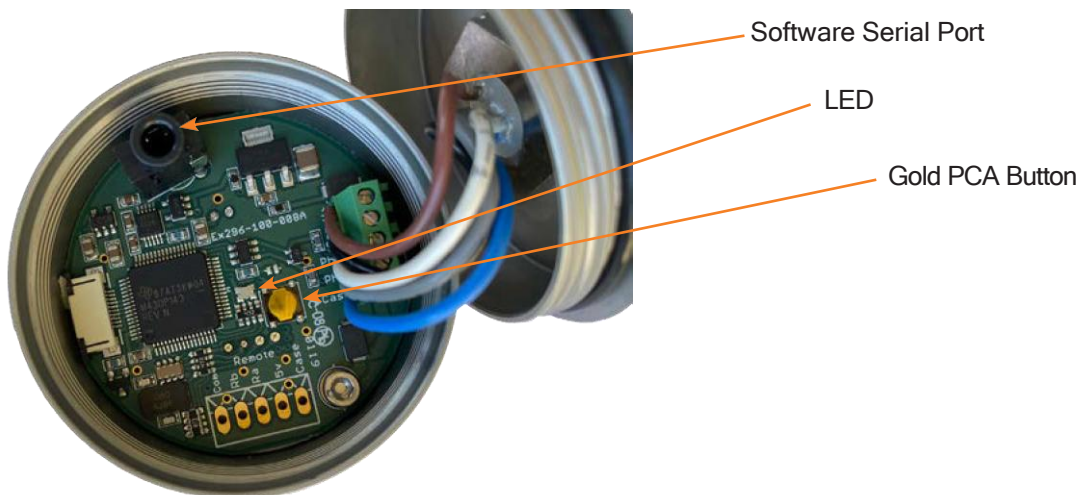

Field Compensation of Transmitter Continued

When a transmitter PCA is replaced or reset in the field, the compensation routine should be performed to optimize the performance of the system. This routine requires a steady flow rate for the flow meter model as shown in Table A below. The flow meter being compensated must not be used for system flow rate feedback control during this process. The transmitter output is disabled during the compensation routine.

If you are unable to run a stable flow in the field, send your meter to Max Machinery for calibration. The compensation routine is as follows:

1. Place your system in 'manual' mode or run it in 'open loop' mode with no flow meter feedback control. Max transmitter output shuts off during field compensation routine. Loss of signal to 'closed loop control' modes can affect the flow stabilization of the system and the compensation of the Max meter.
2. Stabilize the flow rate for your flow meter model as shown in **Flow Rate Table A** below.
3. Activate the compensation routine:
 - a. When using the software via the serial port connection, select 'field compensation' in the software.OR
 - b. If you are NOT using software, push the Gold PCA Button using a non-conductive tool.
4. The blue/green LED will change to solid blue for 5 revolutions of the meter. See table **LED Functions** below on next page for duration of compensation process. Duration is dependent upon flow rate and requires at least 10 seconds at maximum flow and 90 seconds at minimum flow.
5. A green LED light indicates a successful update of the compensation; a red LED light indicates the new compensation failed. Additional information is available through the interface software.
6. Return your system to 'operating' mode or restore settings to allow for feedback control.

Field Compensation Flow Rate Table A

Max Flow Meter	Minimum Flow Rate (cc/min)	Maximum Flow Rate (cc/min)
CGM1	7	15000

LED Functions

Normal Operation		
STATUS	LED	ACTION
Functioning - System Not Flowing	Blue or Green Steady	Meter is functioning, but no flow is detected in the system.
Functioning - System Flowing	Blue / Green alternating colors	Meter is functioning, flow is occurring in the system. Note: At high flow rates the alternating Blue/Green flashes may appear as a single steady color.
Meter Malfunction	Red Steady	Refurbish Meter.
No Power / Meter Failure	No Light	<ul style="list-style-type: none"> - Verify power supply to meter. - Verify wiring follows diagrams on page 4. - If power and wiring are verified, refurbish meter.

Compensation via Interface Software Kit or Gold PCA Button		
STATUS	LED	ACTION
Compensate button pushed/clicked	Blue Steady	- Steady light for 4-5 revolutions of meter.
Compensation Succeeded	Green Steady	<ul style="list-style-type: none"> - Steady light for 5 seconds. - Software will show "Success" on screen.
Compensation Failed	Red Steady	<ul style="list-style-type: none"> - Steady light for 5 seconds. - Software will show "Flow too low/ too high/ unstable" on screen.
<p>Note: Revolutions of meter are dependent on expected fluid flow rate. Per Table A, the maximum compensation flow rate will take approximately 10 seconds, and the minimum compensation flow rate will take approximately 90 seconds to complete 5 revolutions at the stated flow rates.</p>		
<p>If compensation fails, restart the compensation process. When using the Interface Software Kit, follow instructions provided to correct errors prior to attempting compensation again. If problems persist, contact Max Machinery at 707-433-2662 or at www.maxmachinery.com.</p>		

Specifications

CGM1 SPECIFICATIONS

Flow Range	1 cc/min to 2 liters/min
Accuracy (30 cP calibration)	±1.0% of reading over a 100:1 range
Accuracy (3 cP calibration)	±1.0% of reading over a 100:1 range (≤100 psi*)
Maximum Operating Pressure	250 psi (17 bar)
Weight	0.4 kg
Recommended Filtration	10 micron
Port Size(s)	1/8" NPT or 1/8" BSPP
Fluids	Most aqueous and hydrocarbon-based fluids
Typical Fluid pH Range	2 to 13

MATERIALS OF CONSTRUCTION

External	Unfilled PEEK; Stainless Steel, type 303, 316, 17-7; FKM
Wetted	Unfilled PEEK; Zirconia (ZrO ₂)
O-Rings	Standard: FEPM (Fluoroelastomer)** Optional: FFKM (Perfluoroelastomer)

FREQUENCY TRANSMITTER

Output Signal	Standard: 5 Vdc, single phase Optional: Quadrature 5 Vdc, two phase Current sinking, 20 mA max., single phase
K-Factor	Single Phase: 500 pulses/cc Two Phase: 1,000 pulses/cc, 4x decoded (250 pulses/cc/phase, 1x decoded)
Power Supply Requirements	5 - 26 Vdc, at 30 mA
Ambient Operational Range	-15°C to 70°C
Metered Liquid Temp Range	-15°C to 70°C
Compliance	CE Certified - IP65 Rated

ANALOG TRANSMITTER

Output Signal	Any range of ± 10V or ± 20mA, Linearized and damped with anti-dither protection.
Power Supply Requirements	Two Models: 12Vdc at 90 mA, 24Vdc at 45mA
Ambient Operational Range	-15°C to 70°C
Metered Liquid Temp Range	-15°C to 70°C
Compliance	CE Certified - IP65 Rated

*When operating above 100 psi, accuracy over the 100:1 range may increase to +/- 3% of reading.

** Minimum Rated Temp of FEPM Seal Material is -4°C

Specifications

CGM1 SPECIFICATIONS

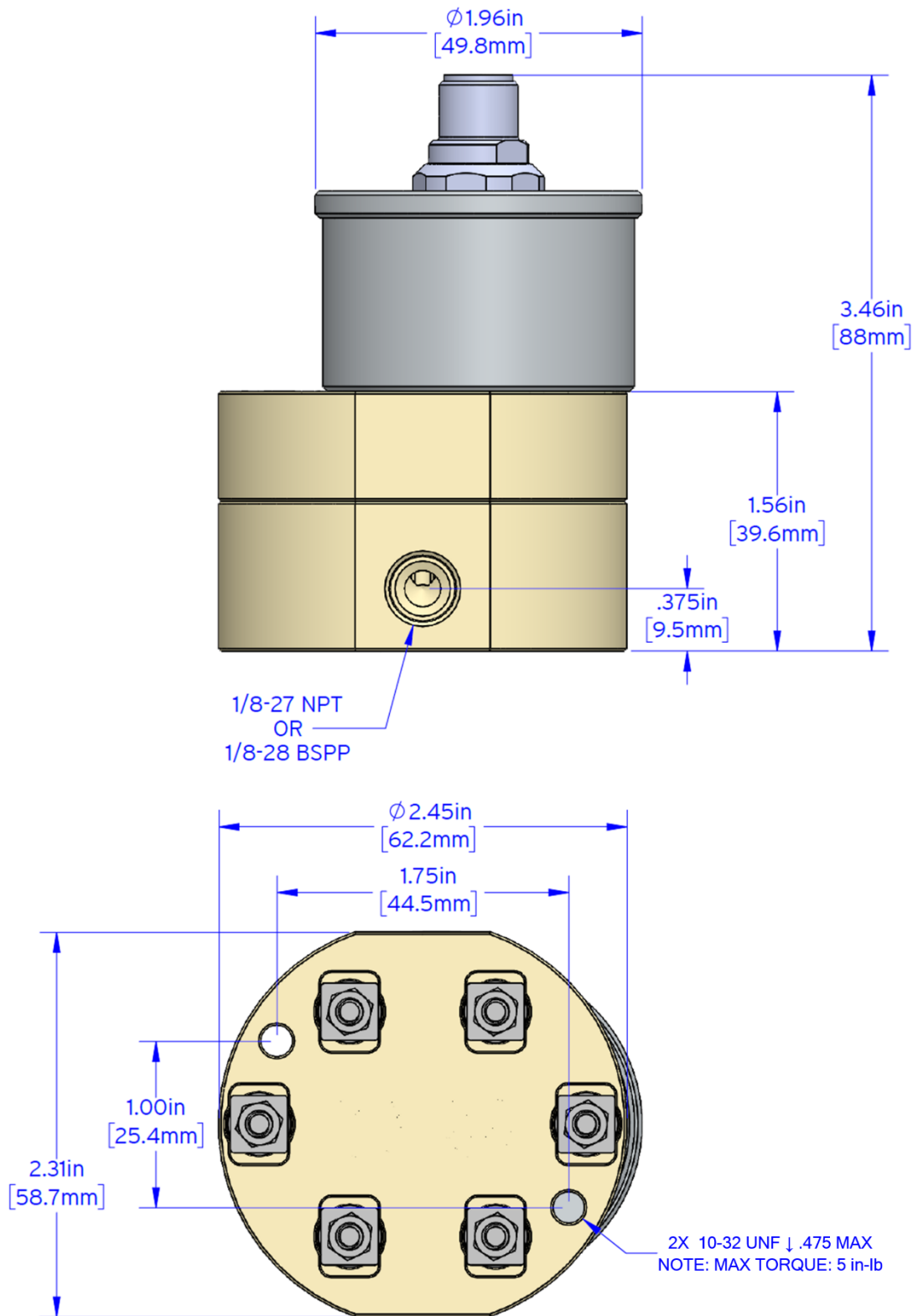

Charts

CGM1 PRESSURE DROP GRAPH

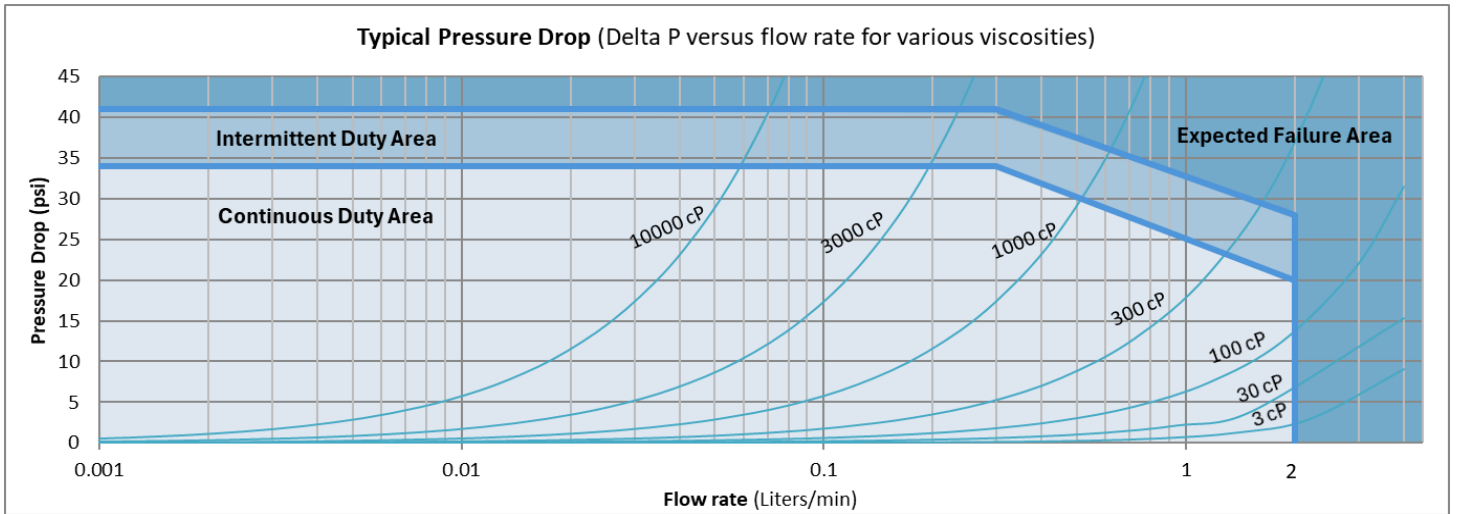

Positive Displacement Flow Meters Gear Type, CGM-Series

Flow Meter Selections Transmitter Selections

Model # LP / / 1 - Non-Standard Options

<p>Max Flow Range 2.0 Liters/Min CGM1</p>		<p>Bi-Directional Cal: BID</p>									
<p>Pressure Rating 250 PSI (17 bar) LP</p>		<p>1 Transmitter Type</p>									
<p>Fluid Connection NPT 1 BSPP 6</p>		<p>Output Type A 4-20mA Output - Powered by 24 Vdc A B 4-20mA Output - Powered by 12 Vdc A C 0-10 Volt Output - Powered by 24 Vdc A D 0-10 Volt Output - Powered by 12 Vdc P N 5V Pulse/Freq. - Powered by 5-26 Vdc Q N 5V Quadrature - Powered by 5-26 Vdc P S Current Sinking, Single Phase</p>									
<p>Seal Selection Fluoroelastomer – FEPM 9 Perfluoroelastomer – FFKM 5</p>		<p>Temperature Rating 1 70°C Industrial</p>									
<p>Options Calibration Viscosity 30 cP C1 Calibration Viscosity 3 cP C2 (Consult Factory) Calibration Viscosity 1cP C3</p>		<p>Electrical Connection 1 Industrial, Turck® Connector</p>									
<p>CGM Viscosity Calibration Guide</p> <table border="1"> <thead> <tr> <th>Application Use Viscosity (cP)</th> <th>Factory Calibration Viscosity (cP)</th> </tr> </thead> <tbody> <tr> <td>≥ 10</td> <td>30</td> </tr> <tr> <td>2 ≤ Use ≤ 10</td> <td>3</td> </tr> <tr> <td>2 or less</td> <td>1</td> </tr> </tbody> </table>		Application Use Viscosity (cP)	Factory Calibration Viscosity (cP)	≥ 10	30	2 ≤ Use ≤ 10	3	2 or less	1	<p>Signal Type P Pulse A Analog Q Quadrature</p>	
Application Use Viscosity (cP)	Factory Calibration Viscosity (cP)										
≥ 10	30										
2 ≤ Use ≤ 10	3										
2 or less	1										

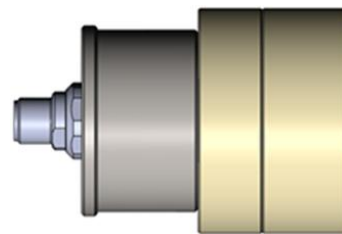

Model CGM1

Available Accessories

Accessories to support your system and simplify your installation and maintenance are available directly from Max. Request yours when you order your flow meter. See the website for information and options.

Interface Software Kit

Part #	Description
SFT-KIT-001	USB drive transmitter programming software and serial cable. The following adjustments may be made to the signal output: Pulse Output Scaling, Analog Output Limits and Scaling, Signal Filtering Options and Compensation settings.



Cables

Part #	Description
181-294-060	7-meter cable - 5-pin Turck® to wire
181-294-061	15-meter cable - 5-pin Turck® to wire

Additional cable lengths are available on the Max website.



Model 122 Combination Rate Indicator/Totalizers 110/220 Vac powered (frequency input)

Model	Description
122-200-000	Panel mount indicator with dual-line, 6-digit display (0.6" and 0.46"). Produces an isolated 4-20mA analog output. Provides 24 Vdc transmitter power. Can be programmed to show rate, total and/or grand total. Initial programming included as default or customer specified values.



F381 Series Filters and Filter Element Kits

Model	Description
F381 - Varies	Inline filter with 5, 10, 30-micron element options. O-rings options available to match your flow meter and system requirements.
381- Varies	Filter element replacement kit with 5, 10, 30-micron element and O-ring options to match your filter.



PCA Replacement Kits

Model	Description
Varies	PCA Replacement Kits are sold for the specific serial number located on your Max Precision Flow Meter. Contact Max technical support for ordering details and to get your quote.



Troubleshooting and Service Request

Problem	Corrective Action
No Flow through meter or high pressure drop across meter	
Solidified material blocking rotation	Heat meter to melt material. Do not exceed maximum meter operating temperature.
Debris damage or internally clogged	Refurbish meter.
Meter broken	Refurbish meter.
Fluid passes through meter, but no flow is indicated	
Transmitter cable or Cable incorrectly wired	Verify DC power is present at the PCA. Use a multi-meter to measure the transmitter output independent of the display or PLC.
Meter not turning	Refurbish meter.
Indicated flow does not agree with expected readings	
Air in the line	Air bubbles displace the meter just like a liquid. If you see over-reporting, purge all air from lines.
Indicator not calibrated properly	Verify K-Factor for the meter in use and compare this value to the setting used in the display.
Excessive reverse flow in system	Max transmitters' anti-dither function buffers up to 1 revolution of reverse flow. An incorrect flow total can be reported if the system reverse flow is greater than 1 meter revolution.

Additional Information Available

MMI provides refurbishment and calibration services. For more details or to submit your Service Request, go to <https://www.maxmachinery.com/services/>.

Additional information about our products, including STEP files and Sample Calibration sheets, may be found on our website at <https://www.maxmachinery.com/downloads/>.

MMI products are covered under our standard manufacturer's warranty. Details may be found at <https://www.maxmachinery.com/warranty/>.

Max Machinery, Inc., 33A Healdsburg Avenue, Healdsburg, CA 95448 USA
707.433.2662 | www.maxmachinery.com

max
Precision Flow Meters